



A Word About Chord Theory

By Christopher Schlegel

Sometimes beginners ask, "Why do we play THESE notes in order to make THIS chord?" This is a great question. The reason we play specific notes to achieve specific chords is an important part of music theory. If you are interested in the theory behind Chord Building then you can learn about it from these [Guitar Tricks Lessons Understanding How Scales and Chords Are Related](#)

For now, though, this tutorial was aimed at simply learning the shapes. At this stage, we are only interested in training your hands and fingers to get used to reaching for and playing these particular positions. With enough repetition we want to get to the point at which you think, "A major chord" and your hands and fingers automatically perform this task.

How much repetition? As much as it takes! It varies for every individual. So take your time and keep at it!

A Major Scale Notes

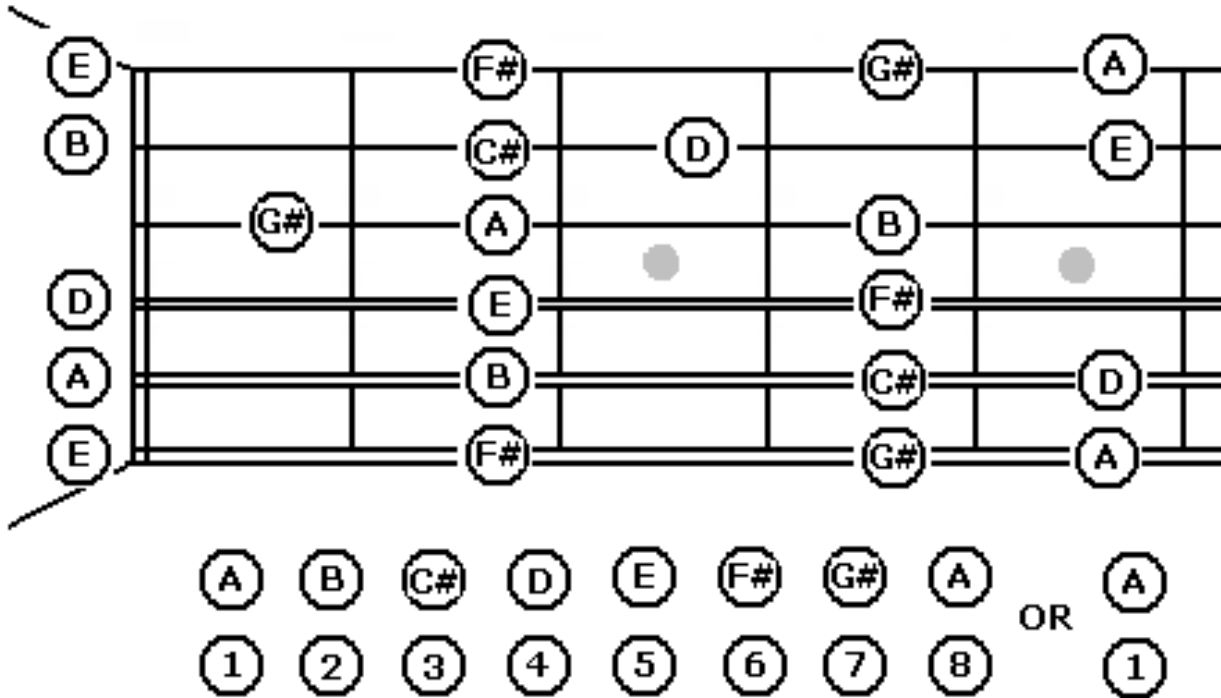

**A Major Chord Notes
in the A Major Scale**

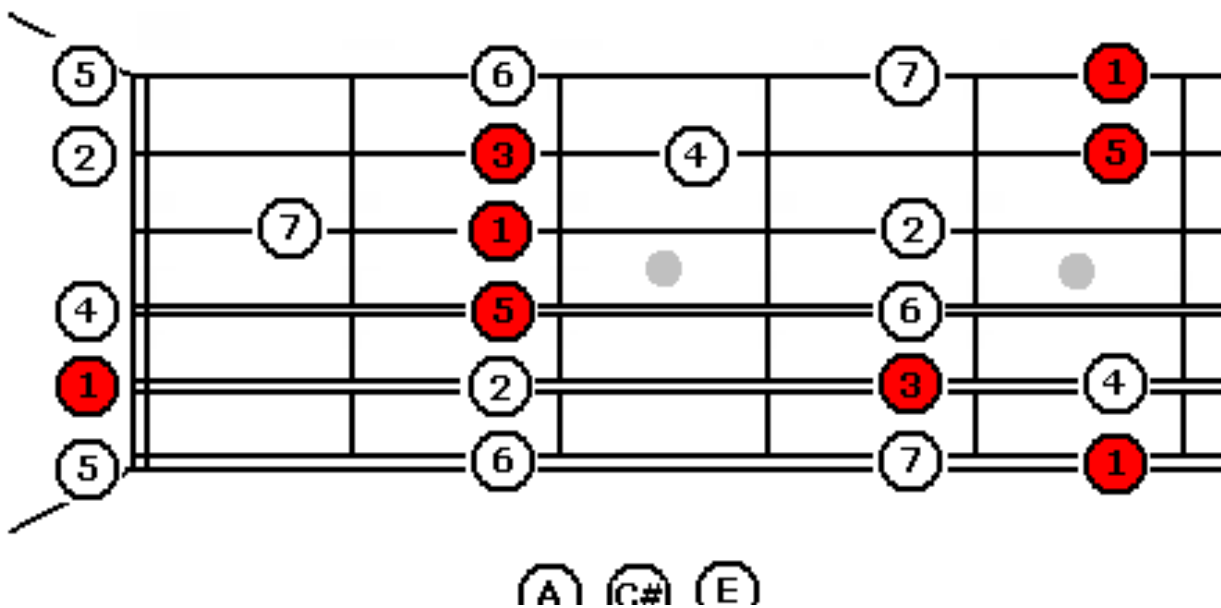

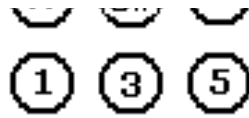

**D Major Chord Notes
in the A Major Scale**

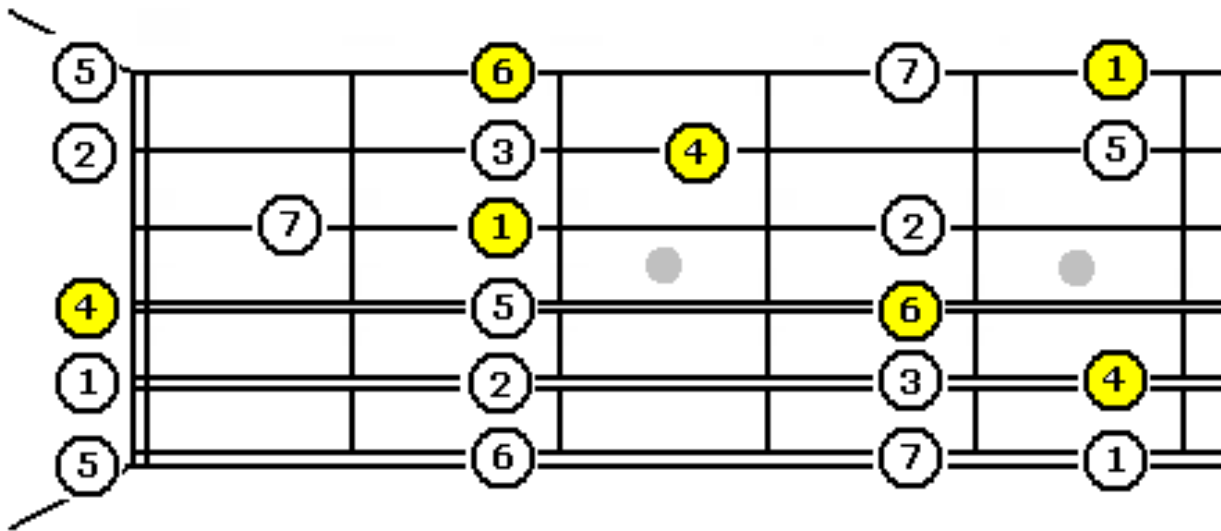

**E Major Chord Notes
in the A Major Scale**

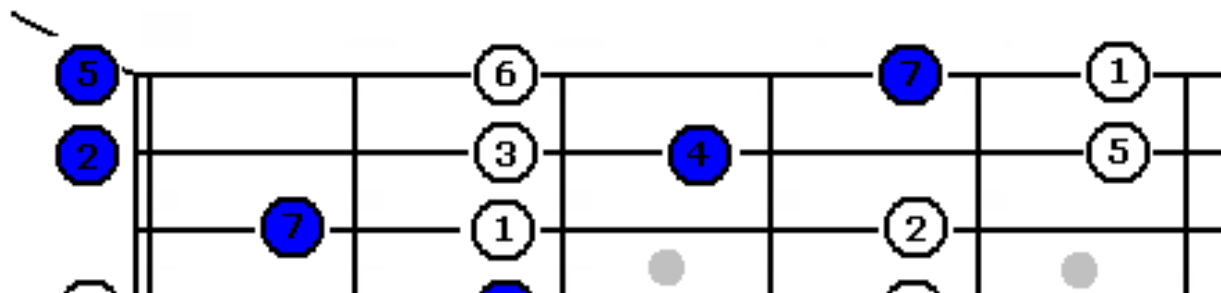

A Word About Chord Theory

By Christopher Schlegel

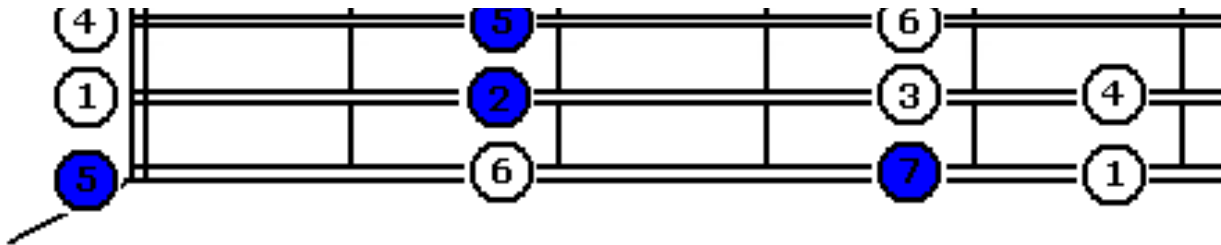

(E)	(G#)	(B)	(And in E7	(D)
(5)	(7)	(2)	also the)	(4)